

Edited by Joan Day

BIAS Journal is possibly the most regularly produced publication, with the longest continuous run, of all the regional industrial archaeological societies. This dependability does have its drawback in being taken for granted but, make no mistake, it is only maintained by considerable voluntary effort from editorial and production teams and, above all, from those carrying out research and producing written results. Our publication has been responsible for a fund of recorded information in fields where, previously, there was little or nothing, and widely appreciated in diverse areas of study. Just occasionally this material has been misused and, to put it bluntly, has been plagiarised by being published elsewhere without permission of authors or editor. A certain amount of tolerance has been exercised where such use has been minimal or has been thought to be in the best interests of industrial archaeology, but BIAS does have a duty to protect the rights of its members from flagrant and illegal breaches of copyright which fall outside such acceptable situations. Positive action has been required during the last year when work of our members has been reprinted without permission, and the copyright act indisputably violated, by an organisation coming under the overall direction of the Avon County Planning Department. An apology has now been received from Dr Stutchbury, County Planning Officer, together with his assurance that this practice will not be allowed to be repeated; nevertheless a close watch will be kept on this and other related situations. In the meantime, may we remind our readers that contributions to BIAS Journal, both written material and illustrations, may only be reproduced with proper acknowledgement, after prior permission has been obtained both from the editor and relevant authors. In this, we can be assured of support from the main body of our members, from BIAS committee, and further afield, the Management Council of the national body, the Association for Industrial Archaeology.

The BIAS Effect

With the formation of BIAS conservation sub-committee, an increasing interest has been taken in planning applications which affect buildings in our area of industrial archaeological importance. In the past year the BIAS point of view has been noted and acted upon in several cases. At times our comments have been particularly requested and it has been possible to build up a valuable rapport with a select few District Council planning officials.

In the centre of Bristol there has been growing concern for some time over the future of 16 Narrow Quay, a building in a prominent position alongside St Augustine's Reach. It is believed to have housed the last surviving sail-making loft in a trade which once dominated this area of the City Docks. Although in poor condition the building was considered by BIAS to be worth saving from demolition and, following our comments, the planning application was refused, but we anticipate that there may be further efforts to secure this important site for new building development.

The past history of Thimble Mill at Bath is a little obscure although the site itself is well-known to canal enthusiasts, standing, as it does, at the entrance from the River Avon to the Kennet and Avon Canal. The building has long been in a delapidated condition, so plans to convert it to a restaurant were viewed in the light of preventing further deterioration. These proposals were felt by BIAS to be appropriate, broadly speaking, but required minor alterations more in keeping with the character of the building. The application was refused initially then, after being re-submitted in an improved form which incorporated some of the BIAS suggestions, was subsequently approved. We received an outline survey of the existing site from the developer and the promise of a set of photographs.

At the request of Woodspring Planning Department a report was produced by a BIAS member on the contents of Gatcombe Mill, between Long Ashton and Flax Bourton, on the River Land Yeo. Surprisingly, this grist mill has escaped previous BIAS attention but survives with its large iron overshot wheel and mainly cast-iron gearing assembly, all in good condition, although lacking some of the timber furniture to its two pairs of stones. BIAS considered that here was a strong case for halting the trend of gutting the few remaining mill-sites with a significant amount of machinery, and the application for conversion to a domestic dwelling was refused. A later proposal to incorporate domestic accommodation with part of the machinery was regarded by BIAS as incompatible with what remained and this was also turned down by the committee. We now await further events but understand that a small group of local enthusiasts, with experience and skills in other aspects of restoration, wish to raise funds to purchase the site to restore the machinery to working condition.

In the last few weeks of 1985 new proposals for Keynsham's Albert Mill have surfaced yet again. This listed Grade II * Industrial Monument has continued to deteriorate through neglect and vandalism since being left unoccupied in 1977- BIAS published a survey of the site in *Journal 7*, 1974 and has since been involved in schemes to arrest the delapidation. These proposals failed largely because the respective commercial developers experienced difficulties in achieving economic viability in using the available space. The latest scheme by Ausnere Properties includes over thirty dwellings to be incorporated in the old mill and new building to be constructed in surrounding courtyards. This intensive occupation of the site is designed to provide means of repairing the old mill building and to conserve the existing machinery and two waterwheels in situ. This new opportunity to restore the mill and its important machinery has been welcomed by BIAS (with certain reservations) and is likely to be viewed favourably by local organisations. At the time of writing, however, the proposals still have to be discussed by the Wansdyke planning committee.

The group acting on behalf of BIAS would be glad to hear from other members who have an interest in this activity,

particularly from those willing to help. Information affecting planning considerations in members' own areas would be very useful, as would the offer to inspect plans at District Council Offices which are only open during the working week. Please contact Roger Wilkes, 15 Dragons Hill Gardens, Keynsham, Bristol.

Great (Western) Disappointment

John Powell, our far-flung member of BIAS Journal's editorial team, recalls the great anti-climax of 1985.

To all but the totally committed Great Western enthusiast, GWR 150 must go down as something of a disappointment. The highlight of the year's celebrations was to be a huge exhibition at Swindon Works at the end of August. Whilst it was widely rumoured that British Rail Engineering had plans to close Swindon Works sometime after the Great Western festivities were over, everyone assumed that Swindon would be allowed to re-live its past glories before any announcement was made. Surprisingly, and with what can only be described as total insensitive timing (and some say deliberately so), British Rail announced total closure details a matter of weeks before the exhibition was due to take place. As a consequence, all Swindon festivities were cancelled, many thousands of enthusiasts were deprived of the opportunity to pay their last respects to one of the greatest railway centres there has ever been, and the high spot of the year was destroyed.

Many other planned events did take place, albeit with somewhat subdued enthusiasm after the Swindon announcement. Bristol was graced with various special steam trains, and thousands turned out to greet them. Unfortunately, some of those destined for Plymouth disgraced themselves further west, and will leave lineside audiences in Devon with less happy memories. Trains to Portishead again were also a welcome sight during the summer.

From time to time it did rather appear that the public relations men and marketing men had been allowed to muscle in on the act in one way or another. The relevance of British Railways diesels (and even a platform luggage trolley at Paddington Station!) in Great Western colours was lost on some, as were such things as Great Western tea-towels and Great Western Roadshows on certain radio stations which were more to do with boosting radio stations than interest in railway history. Raising the price of platform tickets at Temple Meads from 6p to 50p on days when steam trains were calling was nothing short of exploitation.

Bristol is lucky, however, in that it has gained something of lasting value from GWR 150, for restoration of Brunel's Temple Meads terminus was spurred on by the imminence of the anniversary. BIAS was amongst those fighting for this cause as long as 15 years ago (see *BIAS Journal* 4), and now it is hoped that all BIAS members will give the project the total support that it deserves.

Progress on Mayflower

Andy King, Assistant Curator at the Industrial Museum, reports progress on the 'Mayflower' project, in which he has a special interest.

Those members of BIAS who have recently visited the

Industrial Museum cannot fail to have noticed the brightly painted tug lying alongside the quay wall. Astonishment seems the general reaction from visitors when it dawns on them that the ship is *Mayflower*, formerly a rusting pile of some note. Since she disappeared from the front of the Museum in August 1985 and was unceremoniously beached on dry land at Bristol Marina, a great deal has been achieved to improve her seaworthiness and appearance. During fifteen months on dry land, she was shot-blasted, repaired and repainted by a combination of volunteers, begged equipment, and materials, professional assistance from David Abels, Boatbuilders (the only company continuing Bristol's tradition of building working boats), and advice and money from many sources, including BEMA (Bristol Engineering Manufacturers' Association) who have adopted *Mayflower* as their project to celebrate their 50th anniversary this year. Mention must also be made here of the gift of £100 from BIAS, which was of great use to us in the later stages of repair work.

After relaunching the hull at the end of October, we were towed back to the museum on 18th November with a number of representatives of the sponsoring companies aboard. Although hardly a maiden voyage, this little trip served to thank our helpers and to boost the morale of the volunteer team. It also gave us much-needed publicity. Despite her appearance now, *Mayflower* is still a long way from finished. The engine and boiler have to be installed, hopefully in March, and the two cabins require fitting out. To any BIAS member who feels so inclined, I extend an invitation to visit the project on any Wednesday afternoon and evening, perhaps, to lend a hand with the relatively clean and light work which remains to be done on the engine and fittings.

A Successful Achievement at Painters Pit

The culmination of many weekends and long hours of voluntary work brought spectacular results in the Autumn for the BIAS group working at Painters Pit. When the furnace was lit under the ventilation chimney those present were surprised to find just how effective the system could be. 'We set light to some old timbers and the furnace box went off like a jet engine', reported John Cornwell who has been leading the project. This stage of events had been reached after a lengthy and awkward repair to the fire box and lower sections of the chimney, as referred to in these columns of *BIAS Journal* 16. Later it was found necessary to reseal the adjacent pit shaft which contractors, employed by the NCB, had omitted to carry out properly. There is still work to be completed in repairing stonework of the higher sections and the rim of the chimney, and in exposing the features of the horse-gin platform to their best advantage. Those wishing to help with this project at weekends should contact John Cornwell, at 26 Russell Road, Fishponds, Bristol.

Bristol's Copper Slag

Bristol's copper-slag blocks are gradually diminishing in number as building development and road alterations take their toll and, so far, it has not been possible to persuade officialdom that these relics of local 18th century copper-smelting are worth conserving. They have disappeared recently from Blacksworth Road and from the A4 Roadside at Flowers Hill. The early Bristol copper smelters are

believed to have thrown their waste in the River Avon.. Only after being reprimanded for this practice, by the City Council in 1749, did they start to cast building blocks on any large scale as a means of waste disposal. Copper smelting techniques of that period involved up to twelve separate melting operations for each batch of ore, with slag being removed after each melt. It left a massive amount of waste consisting of compounds of silica, iron and sulphur with small proportions of copper remaining and variable trace elements. These are the substances which form these lustrous blue-black blocks, the forerunners of the concrete block. Although brittle and requiring care when moved they make good building material and have an attraction of their own. Those that have survived deserve to remain.

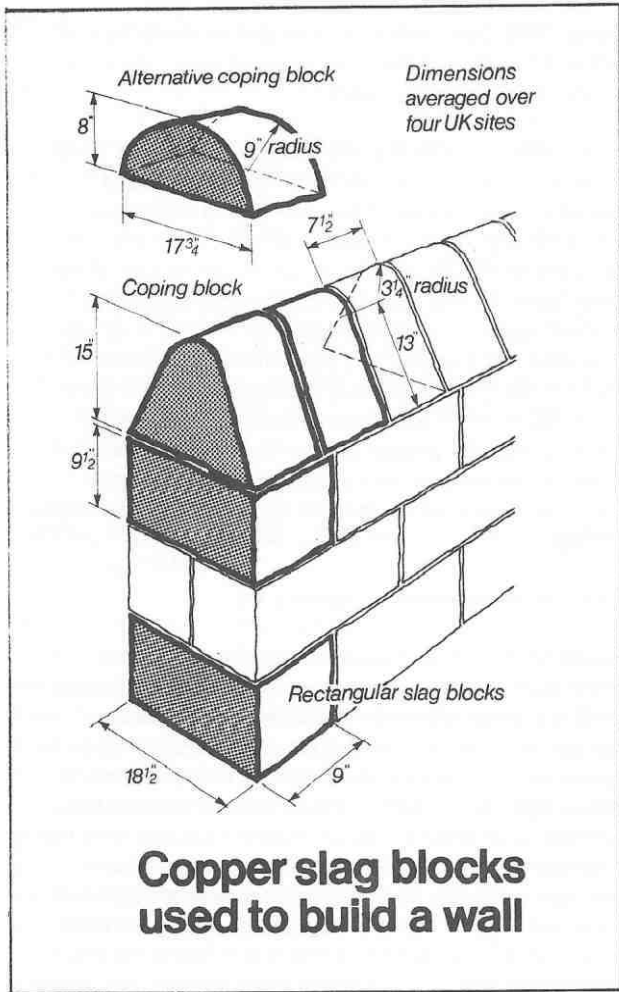

Bristol's blocks have been described in error as zinc slag because they are found near Champion's works at Warmley, but Champion also smelted copper there. The same material has also been referred to as glassworks slag in connection with the early glasshouse established at Newnham. Even lead slag appeared in one description, but these attributions have all been inspired by guesswork rather than analysis of the material. The outlying situation at Newnham is just one of the many sites along the banks of the Severn and Wye which lead to the conclusion that the blocks were used as ballast by small vessels plying in the area. Arllingham, Berkeley and Whitminster are similar sites where they may be seen. In Bristol they appear in large numbers on Siston Common near Warmley House and in Tower Road near the A4 at Newtown Road in Brislington and above all at the Black Castle at Arnos

Vale. Many other sites exist and are worth recording, however, and we appeal to BIAS members to send such locations stating the type, whether half-round or triangular copings or rectangular blocks so that a register may be formed and a marked-up map can be made available to the appropriate authorities. Eric Taylor has agreed to act as collator for this information and can be contacted at 40 Seymour Road, Staple Hill, Bristol BS16 4TF.

Albert Mill

Stop Press: *Ausnere Properties have been given conditional consent to their planning application by the Wansdyke Planning Committee. The proposals still require approval from the Secretary of State for the Environment as the mill is a listed building.*

Obituary

Most of our members will be familiar with the name of Rex Wailes as a great pioneer of industrial archaeology. We are grateful for permission to publish this extract from The Times, 15 January 1986.

Mr Rex Wailes, Renowned Authority on Windmills

Mr Rex Wailes, OBE, who died on January 7 at the age of 84, was the most distinguished man of his time in the study of windmills and watermills, both nationally and internationally. Born in 1901, he was educated at Oundle and served an engineering apprenticeship with Robeys of Lincoln before joining the family engineering firm of George Wailes & Co in 1924. He was one of that rare breed of engineers who take an intense interest in the history of their profession, and he found a very congenial intellectual home amongst fellow-members of the Newcomen Society for the History of Engineering and Technology, which he joined in 1925. He served on the council of the society for many years, becoming president in 1953-55, and delivering a long series of over two dozen authoritative papers on milling. He also joined the Society for the Protection of Ancient Buildings in 1929, and took a leading part in the development of its wind and watermill section. In 1965, he represented Britain at the first international Symposium of Molinology in Portugal. His best-known book, *The English Windmill*, was first published in 1954.

Towards the end of his career, when he was no longer practising as a mechanical engineer, Rex Wailes was employed by the Ministry of Works as it then was, as a consultant on industrial archaeology when this subject had just begun to attract national attention in the late 1950s and early 1960s. From 1963 to 1971 he performed this role as the officer to the newly-established Industrial Monuments Survey administered by the Council for British Archaeology, fulfilling a remarkable programme of pioneering activities. He travelled over much of the country, identifying industrial monuments requiring protection, laying the basis for the recording of such monuments, and undertaking countless lectures as a result of which many local societies and conservation trusts were formed, inspired by his crusading spirit. National bodies like the Royal Commission on Historical Buildings in England and the National Trust also have cause to be grateful to him for his advice. He was made the OBE in 1971 in recognition of these services.